

# TWILIGHTNING

**Sound tech rider  
version 14.03.2007**

Sound system requirements:

F.O.H

-mixing console:

- minimum 24 inputs & 4 stereo inputs

- 8 VCA's

- preferred consoles:

  - Midas Heritage & XL series

  - Yamaha PM-4000 & 5000

  - Soundcraft Series 5

-dynamics & FX:

- 5 ch comp (BSS, dbx, KT)

- 8 ch gate (Drawmer, KT)

- 1 delay with tempo tap (TC D-2, SDE3000)

- 1 SPX 990 (SPX-900)

- 2 reverbs (Lexicon PCM series, TC M2000-5000)

-misc:

- MD for recording

- CD for playback

- talkback to stage

Mon.

-mixing console:

- minimum 24 inputs

-dynamics:

- 2 ch gate

- 1 ch comp

- 4 mixes with 31 band eq's

- 4 wedges (2x12"+1") & drumfill (2x15"+2")

# TWILIGHTNING

Input list  
version 14.03.2007

Ch	Instrument	Mic	Insert	Attn.
1	Kick 1	B 52	Gate 1	Mon. gate 1
2	Kick 2	B 52	Gate 2	Mon. gate 2
3	Snare top	SM 57	Comp 1	
4	Snare bottom	SM 57	Gate 8	
5	Hihat	SM 81		
6	Rack tom 1	Beta 98	Gate 3	
7	Rack tom 2	Beta 98	Gate 4	
8	Rack tom 3	Beta 98	Gate 5	
9	Rack tom 4	Beta 98	Gate 6	
10	Floor tom	Beta 98	Gate 7	
11	Ride	SM 81		
12	Oh SR	C 414		
13	Oh SL	C 414		
14	Bass line	Active DI	Comp 2	
15	Bass mic	B 52		
16	Gtr SR	SM 57		
17	Gtr SL	SM 57		
18	Voc SR	SM 58	Comp 3	
19	Lead Voc	Wireless SM 58	Comp 4	Mon. comp 1
20	Voc SL	SM 58	Comp 5	
21	HD Back voc	XLR		
22	HD Back voc	XLR		
23	HD Key	XLR		

page 2/3

Any questions?  
Please dial +358 40 579 4003,  
or send e-mail to [info@twilightning.net](mailto:info@twilightning.net)

# TWILIGHTNING

Stage  
version 14.03.2007

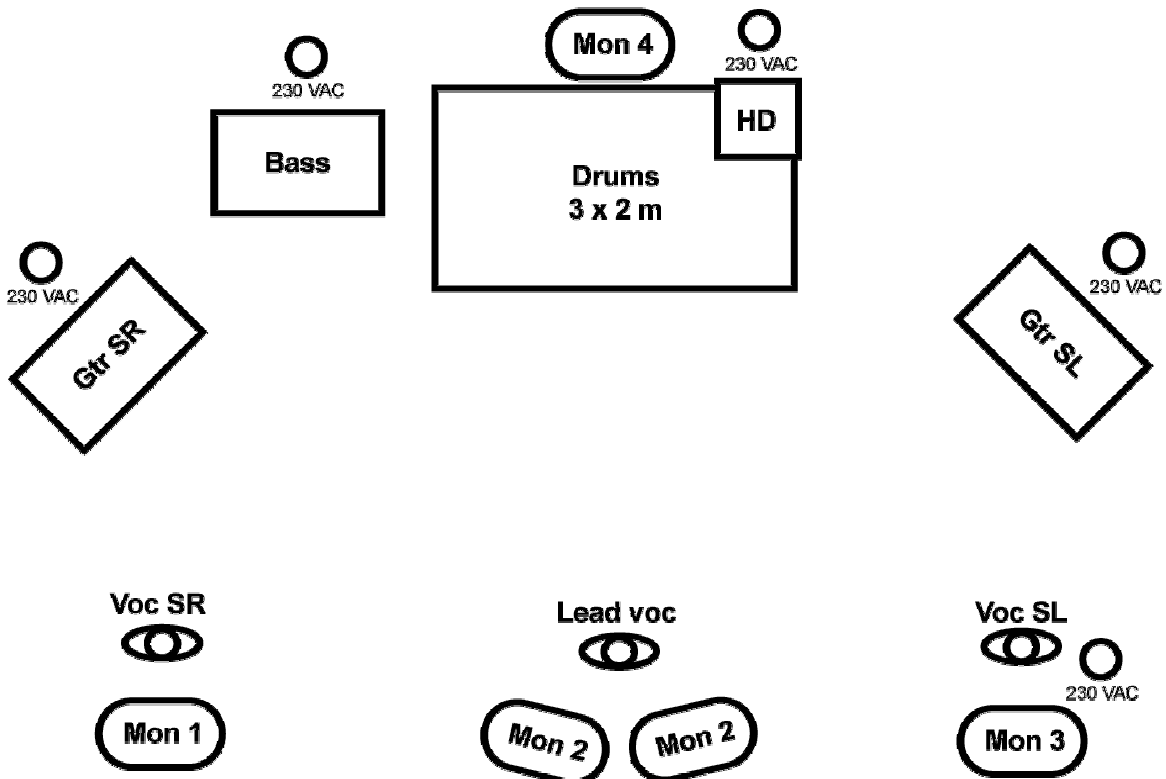

page 3/3

Any questions?  
Please dial +358 40 579 4003,  
or send e-mail to [info@twilightning.net](mailto:info@twilightning.net)